

PKS-PRO-AEA-EC-50 - EtherCAT Servo System



FEATURES

- Updates 1000 Inputs/Outputs of Information
- Rated Torque of 3384 oz-in
- Power Ratings up to 5000 Watts
- Open Network Based on Ethernet
- 17-bit Absolute Encoder
- Maximum Speed of 3,000 RPM
- Supports Topologies - Line, Tree, and Star Type
- Brake Option Available
- CE Certified



DESCRIPTION

The PKS-PRO-AEA-EC-50 EtherCAT Servo System includes a 5000 Watt EMG-50 Servo Motor operated by the PRONET-50AEA-EC EtherCAT Servo Drive. These packages are ideal for easy start-ups, convenience, and performance. The Servo Motors included in these packages provide up to 3384 oz-in of Rated Torque. The PRONET-50AEA-EC Drive offers current forward-feedback control, acceleration forward-feedback control, speed viewer, Ethernet networking, and inertia viewer; providing for improved response performance. Each system includes a 5m Motor Power Cable and a 5m Encoder Cable.

Item	Rated Voltage (VAC)	Rated Speed (RPM)	Rated Torque (oz-in)	Rated Current (Arms)	Inertia (oz-in-sec ²)	Torque Constant KT (oz-in/A)	Resistance (ohms)	Inductance (mH)	Brake (24VDC)	Motor Length (mm)	Shaft Diameter (mm)
PKS-PRO-AEA-EC-50-GP22	200	2000	3384	28	0.9303	120.6	0.1	1.23	No	278	35
PKS-PRO-AEA-EC-50-GP24	200	2000	3384	28	0.9757	120.6	0.1	1.23	Yes	349	35

ORDERING INFORMATION

PKS-PRO-AEA-EC-50-GP22

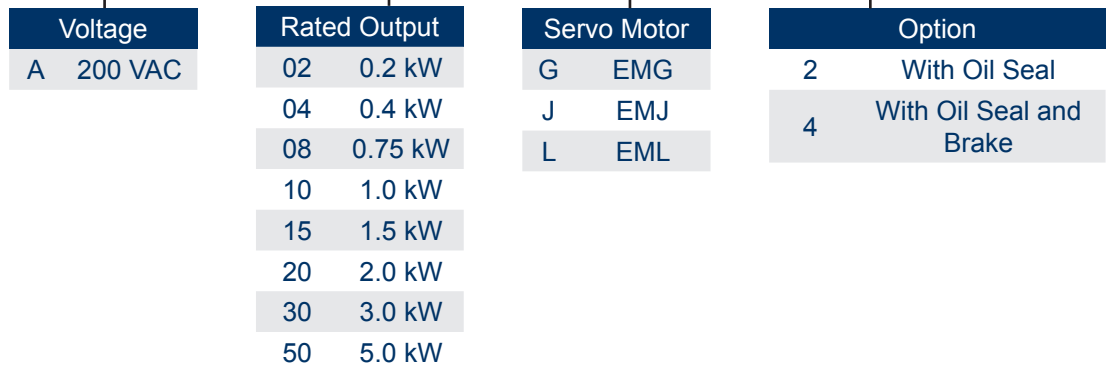

L011578

EMG-50 Motor Specifications



FEATURES

- 220 VAC
- **Rated Torque of 3384 oz-in**
- **5000 Watt Power Rating**
- **Rated Speed 2000 RPM**
- **Maximum Speed 3000 RPM**
- **Peak Torque up to 300% of Rated Torque**
- **Peak Current up to 300% of Rated Current**
- **131,072 PPR Absolute Encoder Attached**
- **Enclosed and Self-Cooled**
- **Brake Option Available**
- **CE Certified**



SPECIFICATIONS

Model #	Rated Torque (oz-in)	Rated Power (Watts)	Rated Speed (RPM)	Max Speed (RPM)	Rated Current (A rms)	Brake (24VDC)	Inertia (oz-in-sec ²)	Torque Constant K _T (oz-in/A)	Resistance (ohms)	Inductance (mH)	Length (mm)	Weight (lbs)
EMG-50ASA22	3384	5000	2000	3000	28	No	0.93039	120.6	0.1	1.23	278	53.5
EMG-50ASA24	3384	5000	2000	3000	28	Yes	0.9757	120.6	0.1	1.23	349	61.5

TORQUE CURVE

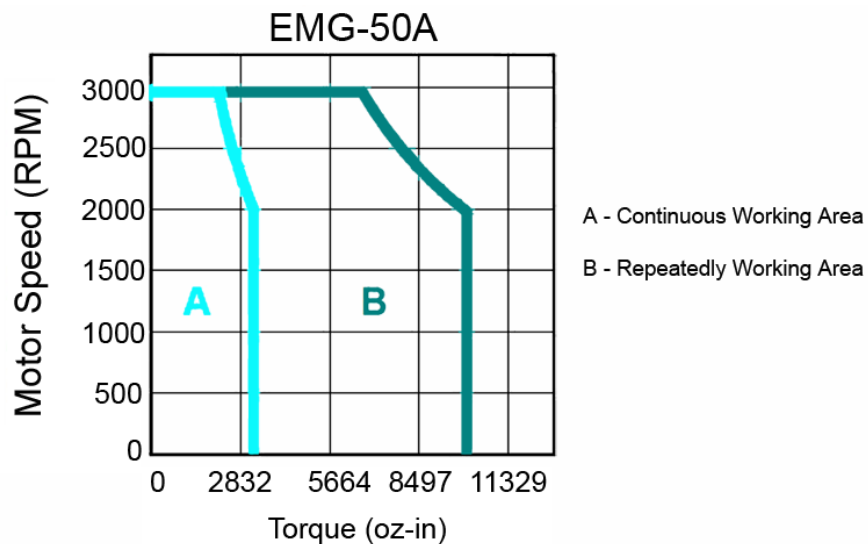

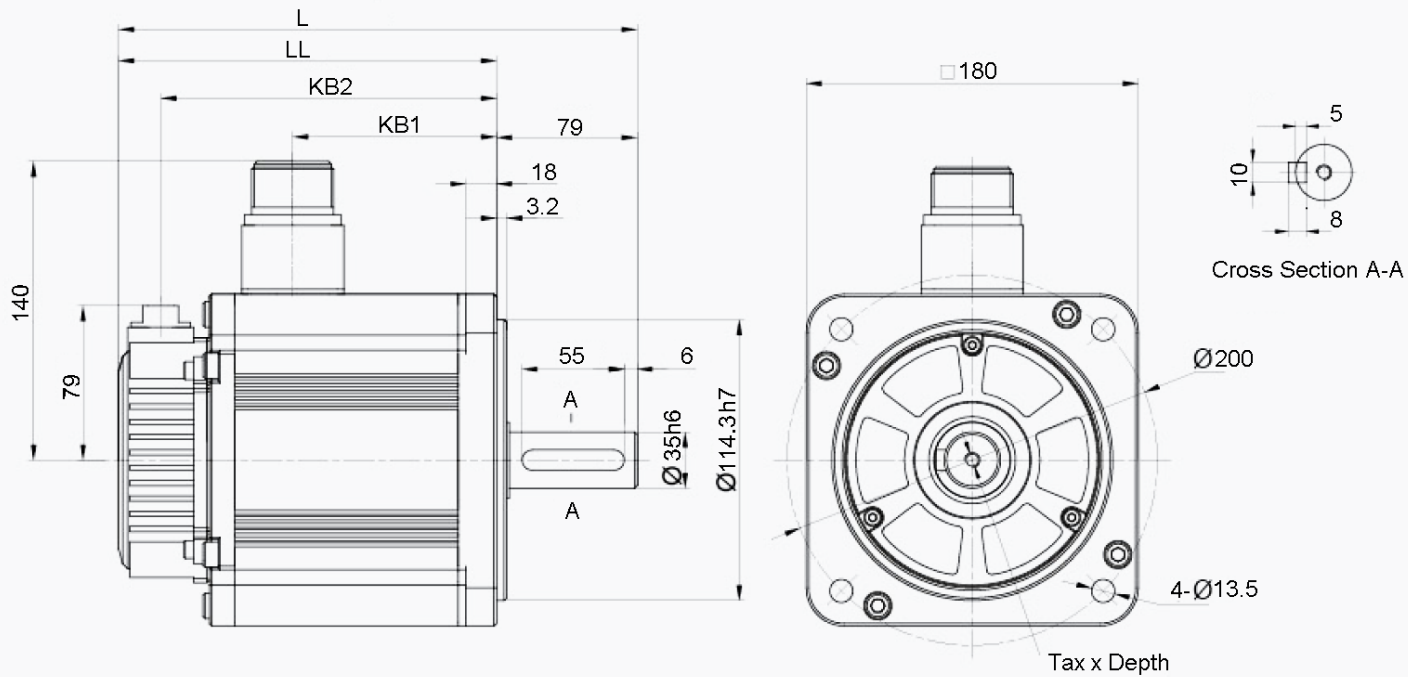

Note: All Dimensions in millimeters

Model #	L	LL	KB1	KB2
EMG-50ASA22	357	278	183	253
EMG-50ASA24	428	349	183	324

Note: the EMG-50ASA24 are Servo Motors with holding brakes.

Encoder Connector Specification:



Pin No.	Signal
K	S+
L	S-
T	BAT+
S	BAT-
H	PG5V
G	PG0V
J	FG

Motor Connector Specification:



Pin No.	Signal
A	U
B	V
C	W
D	FG

Brake Connector Specification:



Pin No.	Signal
A	B1
B	B2
C	-

Power Requirement: 220VAC	Vibration: 49 m/s ²	Running Air Pressure: 86 to 106 kPa
Insulation Class: F	Ambient Temperature: 20% to 80% RH	Insulation Voltage Endurance: AC 1800C, 50Hz, 1 min
Ambient Temperature: 0°C to 40°C	Running Humidity: Not More Than 90%, Under 25°C	Insulation Impedance: Not Less Than 50M Under Normal Conditions
Running Temperature: -25°C to 40°C		

Compatible Driver:

Part Number	Description
PRONET-50AEA-EC	Servo Driver



Compatible Cables

Part Number	Description
PDM-GD12-05	Power Cable
PAP-GA24-05	Encoder Cable



PRONET-50AEA-EC EtherCAT Driver Specifications



FEATURES

- Power Rating of 5000 Watts
- 100 BASE-TXI Twisted-Pair Wire, 100 BASE-FX Fiber, or LVDS (Low Voltage Differential Signaling)
- Supports Topologies - Line Type, Tree Type and Star Type
- Open Network Based on Ethernet
- Capable of Updating the Information of 1000 I/O
- Exchange of Frame as Big as 1486 Bytes



DIMENSIONS

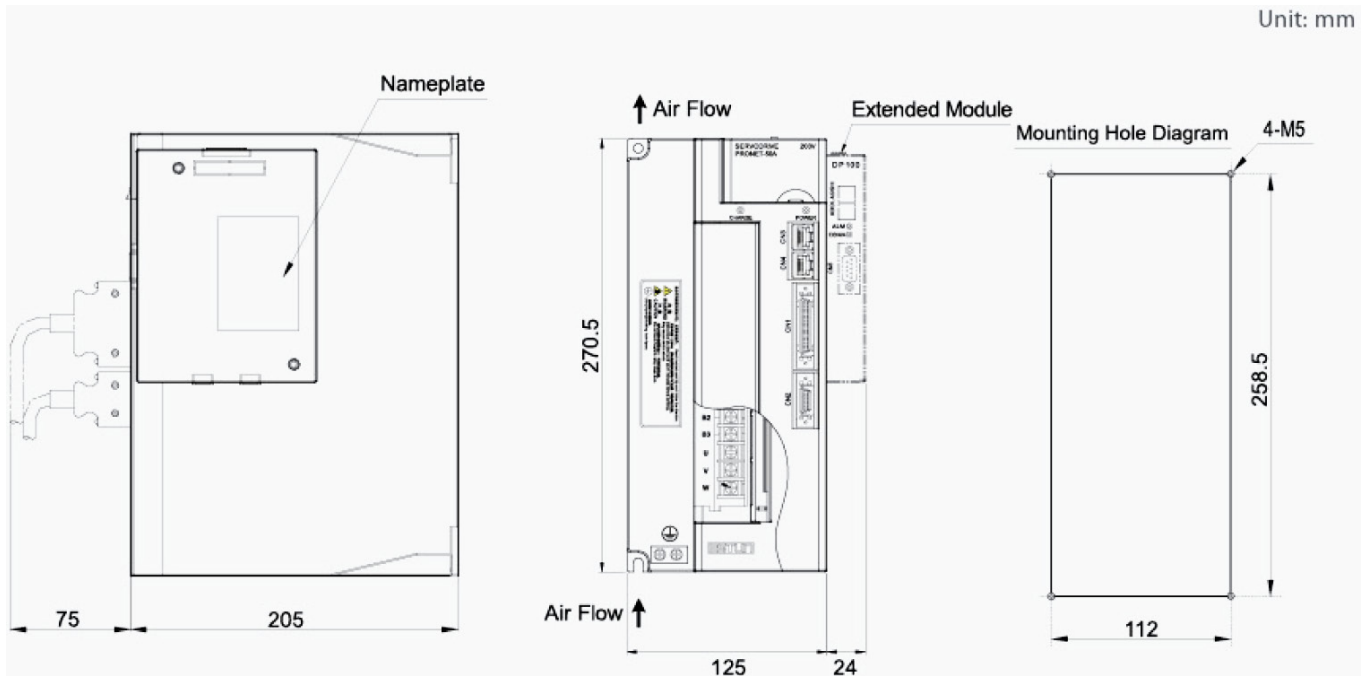

Item	Rated Power (Watts)	Rated Voltage	Drive Control Capabilities	COMM	I/O Signals
PRONET-50AEA-EC	5000	200VAC	Position, Speed, Torque	EtherCAT	5 Inputs 3 Outputs

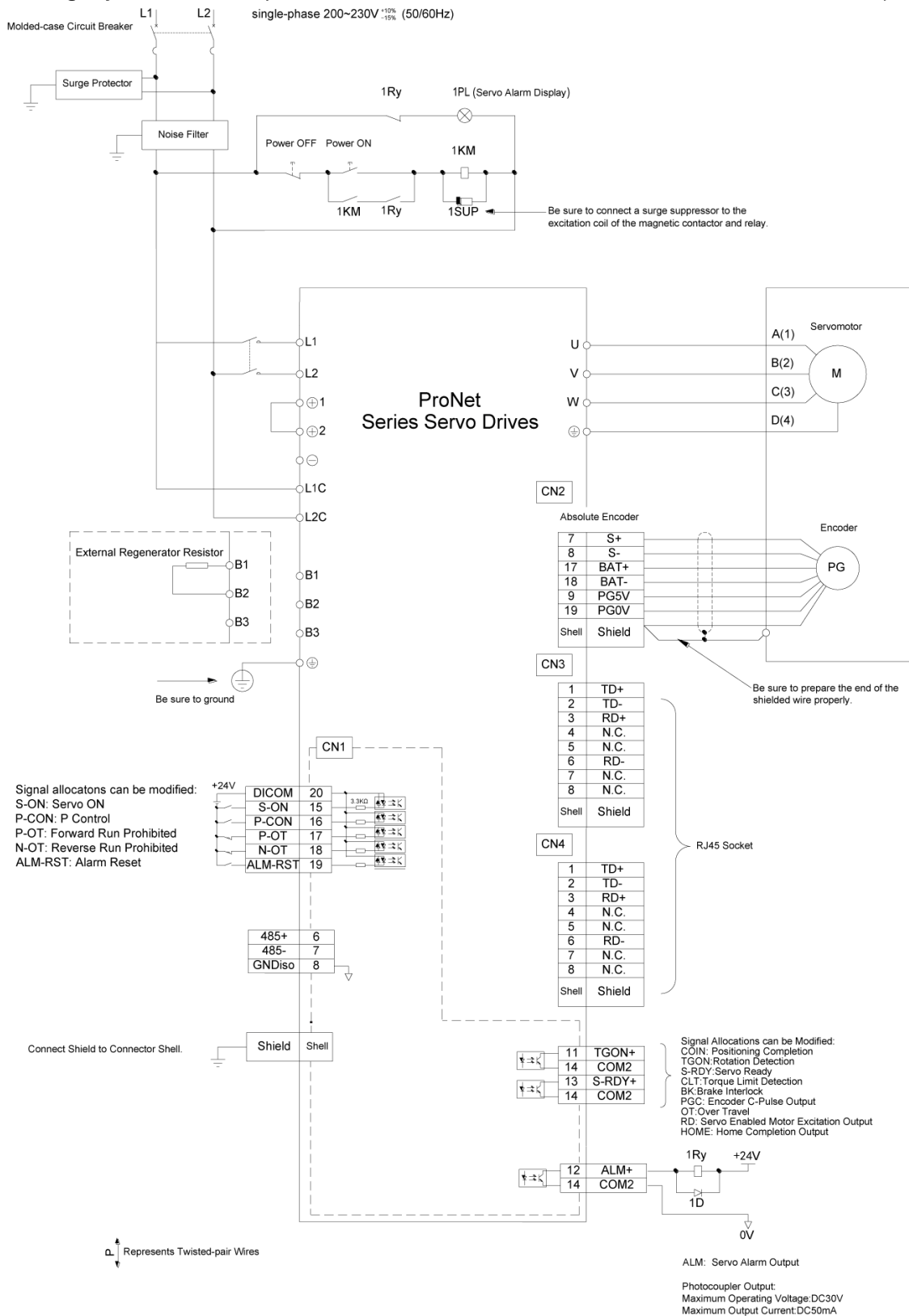

Compatible Drivers

Part Number	Description
PRONET-50AEA-EC	Servo Driver



Compatible Motors

Part Number	Description
EMG-50ASA22	Servo Motor
EMG-50ASA24	Servo Motor



Compatible Cables

Part Number	Description
PDM-GD12-05	Power Cable
PAP-GA24-05	Encoder Cable

